

# The Nation.

## Advertising Specifications

Recognized agencies earn a standard 15 per cent discount. Discounts apply only within the contract year and must be negotiated in advance. It is understood that the advertiser and/or agency indemnifies the publisher against any claims or suits based on the contents of an advertisement. The publisher reserves the right to reject or cancel any advertising at any time. Publication of an advertisement constitutes final acceptance. *The Nation* has a strong presumption against censoring any advertisement.

### BLACK AND WHITE ADS:

Please supply right-reading, emulsion-side-down film negatives with a line screen of 85 lpi. Include a positive proof such as a good quality laserprint or a photostat. You may also supply camera-ready mechanicals. *The Nation* is offset printed on an uncoated stock and is saddle-stitched.

### COLOR ADS:

Please supply right-reading, emulsion-side-down film negatives with a line screen of 100 lpi including all color separations. Include a positive proof such as a matchprint or chromalin. You may also supply camera-ready mechanicals. *The Nation* is offset printed on an uncoated stock and is saddle-stitched.

**2-PAGE SPREAD (WITH BLEED)**

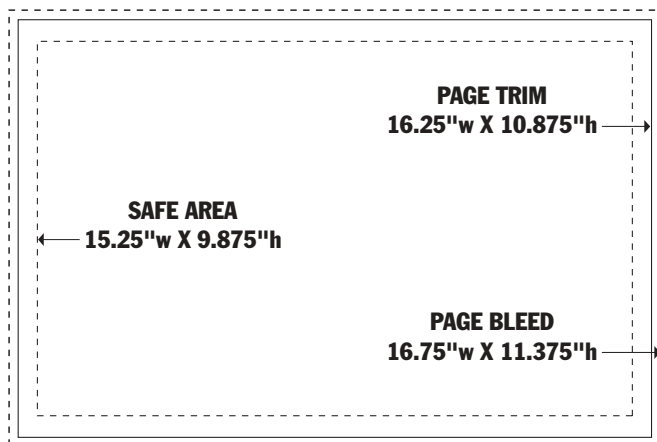

**FULL-PAGE AD (WITH BLEED)**

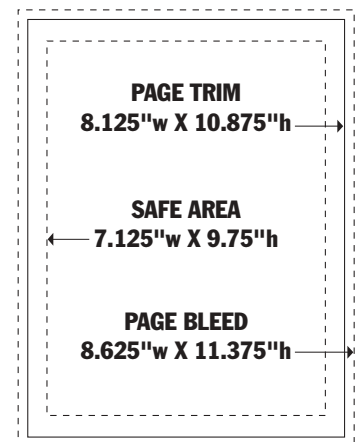

*continued on next page*

# Advertising Specifications (continued)

**FULL-PAGE AD (NO BLEED)**

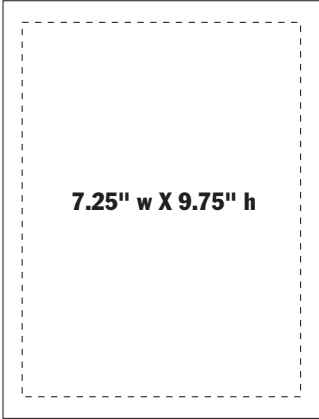

**2/3 PAGE**

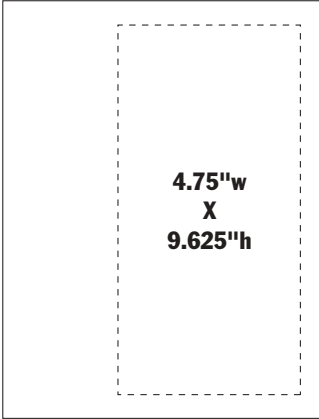

**1/2 PAGE ISLAND**

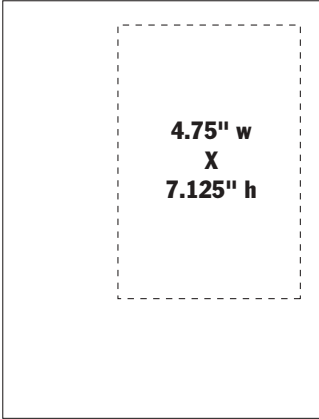

**1/2 PAGE HORIZONTAL**

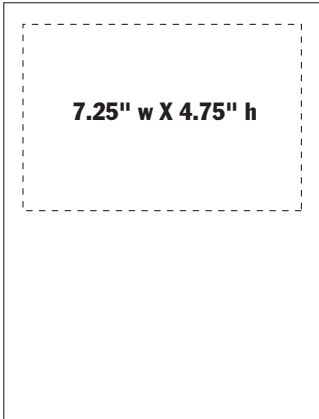

**1/2 PAGE VERTICAL**

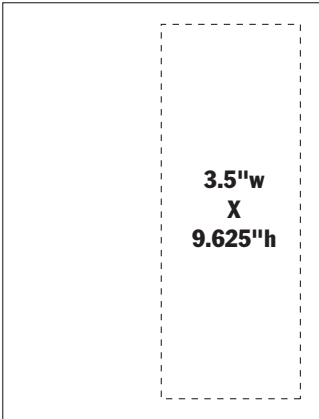

**1/3 PAGE VERTICAL**

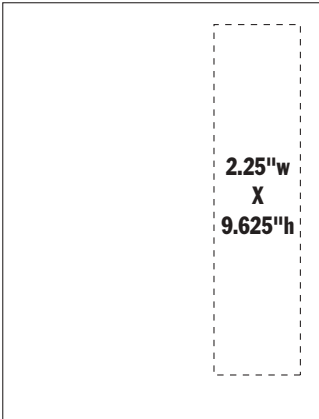

**1/3 PAGE SQUARE**

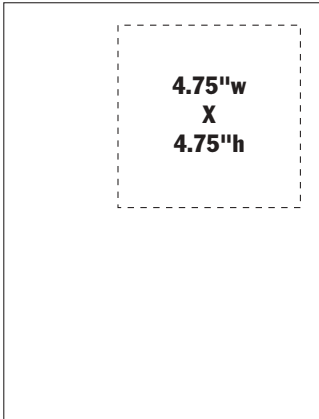

**1/4 PAGE AD**

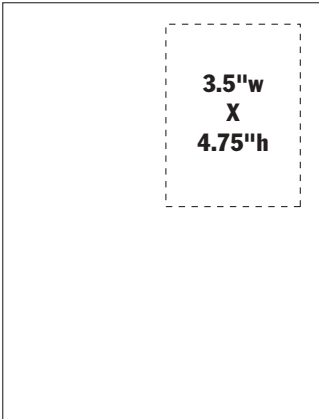

**1/6 PAGE AD**

